

Strategic Partnerships

Greater than the Sum of the Parts



CNSI Background

- CNSI is a leading solution provider in the MMIS space
- Awarded Michigan's MMIS Replacement DDI in 2005 with subsequent Operations Support contracts
- CHAMPS sits at the center of a large Medicaid footprint in the State of Michigan
- Strengths in the areas of innovation and technology
- Matured from Vendor to Strategic Partner



Aligning
Technology
for
Success

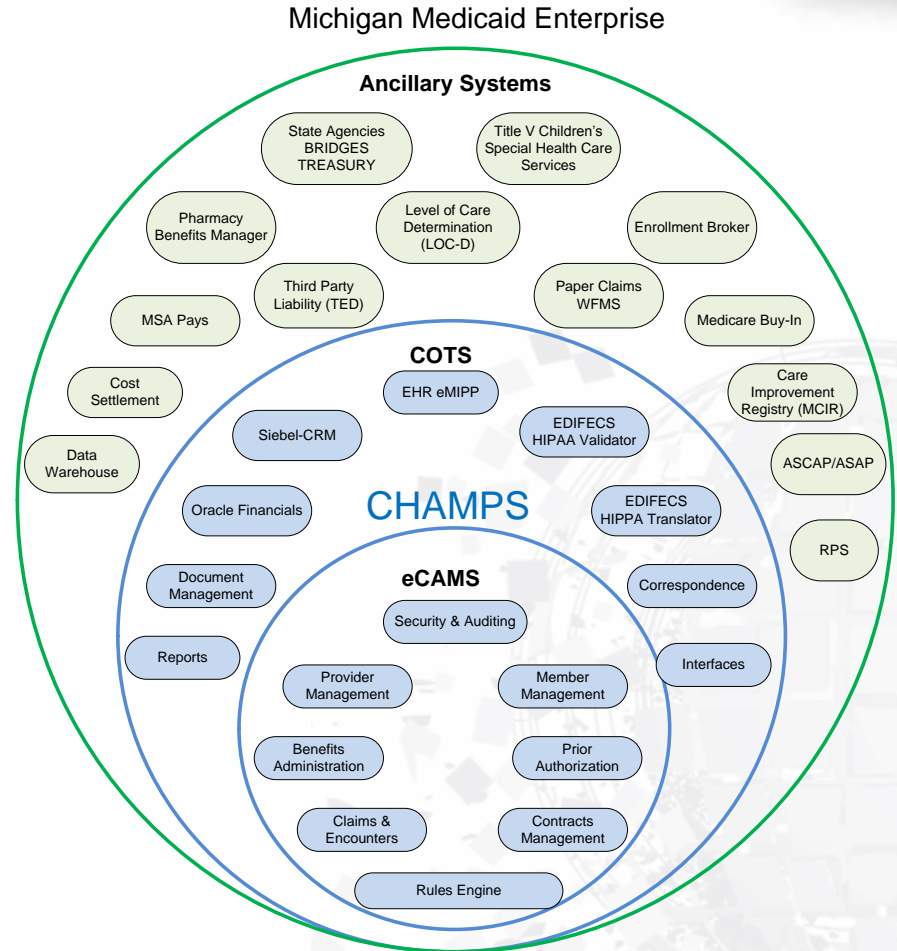

Conference Theme

“Cultivating Relationships and Opportunities to Share and Succeed”

Strategic Partner

stra·te·gic

/strə'tējɪk/ 

adjective

relating to the identification of long-term or overall aims and interests and the means of achieving them.

"the company should take strategic actions to cope with fundamental changes in the environment"

synonyms: planned, calculated, tactical, politic, judicious, prudent, shrewd

"his lawyers were known for their strategic defense methods"

- carefully designed or planned to serve a particular purpose or advantage.
"alarms are positioned at strategic points around the prison"
- relating to the gaining of overall or long-term military advantage.
"New Orleans was of strategic importance"

part·ner

/'pɑːtnər/ 

noun

1. a person who takes part in an undertaking with another or others, especially in a business or company with shared risks and profits.
synonyms: colleague, associate, coworker, fellow worker, collaborator, comrade, teammate; *archaic* compeer
"business partners"
2. NAUTICAL
a timber framework secured to and strengthening the deck of a wooden ship around a hole for a mast.





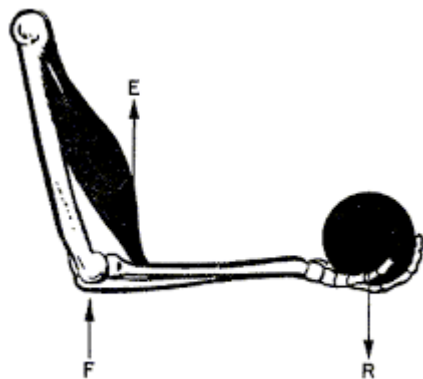

Figure 1-6-Your arm is a lever.

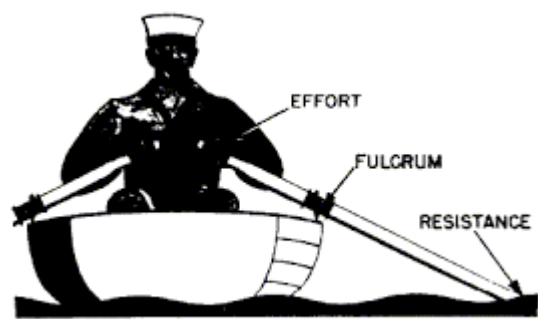

Figure 1-3-Oars are levers.

Gears are levers arrayed in a circle...

Where gears meet they **MESH**

ANOTHER CHALLENGE
Can you make a gear system activate a lever system!

RACK AND PINION MECHANISM

The diagram shows two gears of different sizes meshing together. Curved arrows indicate their opposite directions of rotation. A callout box points to the contact point between the teeth. Below this, a box contains the challenge text. To the right, a rack and pinion mechanism is shown, consisting of a circular gear meshing with a vertical rack. A curved arrow shows the gear rotating, and a straight arrow shows the rack moving upwards.

In science, a machine is anything that
makes a force bigger.

=

Force Multiplier

In life, relationships are a force multiplier
and
In business, partnerships are a force
multiplier

Partnership Definition

An extended relationship between buyers and sellers based on confidence, credibility and mutual benefit.

-- Council of Supply Chain Management Professionals



Another Partnership Definition

A commitment over an extended time to work together to the mutual benefit of both parties, sharing relevant information and the risks and rewards of the relationship. These relationships require a clear understanding of expectations, open communication and information exchange, mutual trust and a common direction for the future.

-- Institute for Supply Management

Working Man's Definition of Partnership

- Meshing two forces together to multiply force or speed.

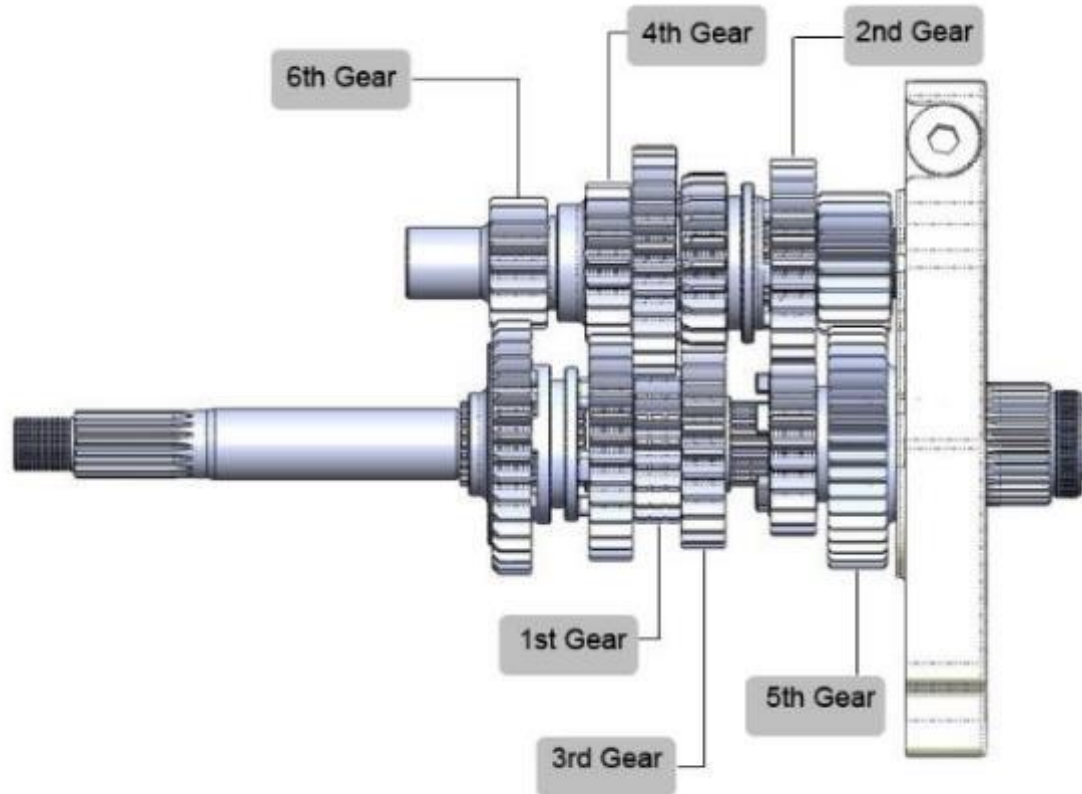

Plane Crash That Killed Tower Is Blamed On Stripped Gear



By Gregory Spears, INQUIRER WASHINGTON BUREAU This article contains information from the Associated Press

POSTED: April 29, 1992

WASHINGTON — A stripped gear in a propeller control caused the nose-dive plane crash that killed Sen. John Tower and 22 others last April, the government concluded yesterday.

Atlantic Southeast Airlines Flight 2311, a two-engine Embraer 120 built in Brazil, crashed on April 5, 1991, while approaching the Glynco Jetport at Brunswick, Ga. The dead included Tower, his daughter, Marian, and astronaut Manley Lanier "Sonny" Carter.

A gear that adjusted the pitch of the left engine's propellers was worn away by an opposing part with a harder titanium coating, the National Transportation Safety Board said yesterday.

"It acted like a file and over time it wore down the teeth that controlled the propeller," said acting board chairwoman Susan Coughlin.

The two parts disengaged, changing the angle of the propeller blades.

The safety board's report said that failure of the system caused a lift and drag condition "that exceeded the capability of the pilots to counteract with the airplane controls available."

The board absolved the plane's captain, Mark Friedline, of any blame, saying he was an experienced pilot known for rigorously testing his aircraft's engines before flight.

But it said that the design by the propeller manufacturer, Hamilton Standard Corp. of Windsor Locks, Conn., had contributed to the accident, along with the FAA approval of that design.

A spokesman for Hamilton Standard said the company, a division of United Technologies, could not comment because it is being sued for damages by Tower's estate and the estates of other victims of the crash.

The NTSB called on the FAA to review the design of the propeller control system and make appropriate changes.

Shortly after the accident, the FAA ordered inspections of the propeller control gear on the 350 other Embraer EMB-120 aircraft in service in the United States.



A Partnership is NOT...

- Contracts and Agreements
- A solution to a singular problem or event
- About the technology per se'
- A tool used by vendor/supplier to get more from the other party without reciprocation
 - Remember Atlantic SE flight 2311



Principles that “Mesh” Together

Our Guiding Principles



Mission

The Michigan Department of Community Health will protect, preserve, and promote the health and safety of the people of Michigan with particular attention to providing for the needs of vulnerable and under-served populations.

Vision

Improving the experience of care, improving the health of populations, and reducing costs of health care.

Leadership, Excellence, Teamwork

Priorities that “Mesh” Together

Michigan Department of Community Health 2015 Strategic Priorities

Promote and Protect Health, Wellness, and Safety

Improve Outcomes for Children

Transform the Healthcare System

Strengthen Workforce and Economic Development



A Partnership is...

- Leadership being on the same page...
- About adding long term value to both parties
- About complimenting the other
- Give and Take / Trust and Respect / Shared Risk & Reward
- About open communication and clear governance
- Reinforcing behavior that benefits both parties
- About “meshing” together

Closing Thoughts

- What does “Cultivating Relationships and Opportunities to Share and Succeed” mean?
- Where do we need to multiply force or speed?
- Where can we find partners to “mesh” with in our every day work?
- What behaviors reinforce trust and long term value creation?
- How can we lead in the position we are in today?



THANK YOU!

Bret Baker
*Director, Program Management Office
Midwest Region*

CNSI
6465 Millennium Drive, Lansing, MI 48917
t: 517.321.3133 | bret.baker@cns-inc.com

